



Le mani per il vostro carrello

Forche a nastro · Forche telescopiche
T180FG · T180FG-2-4S



T180FG-2-4S

An unique attachment for handling goods with or without pallets

Innovative attachment technology for universal material handling

The revolution in efficient material handling - one attachment for handling palletised as well as palletless goods. In logistics world wide at airports and ports, during in-plant loading and unloading of goods, or in production transferring goods from in-house load units to shipping pallets, one often encounters goods which must be handled without pallets and which, due to nature of the goods, cannot be clamped. Traditionally push-pulls, pallet turnover clamps or other solutions are used. When transporting palletised goods an additional forklift truck with forks is required or attachments must frequently be fitted to and removed from the machine which is extremely time consuming.

KAUP conveyor belt forks combine both disciplines in one attachment and considerably broaden the field of application for your forklift truck. They can be used in all conceivable branches of industry - ranging from building materials, consumer goods, food to cement and substantially contribute, as an efficient material handling solution, to increased economic efficiency.

Future-oriented technology sets new standards

Simply genius and ingeniously simple - the functionality of conveyor belt forks

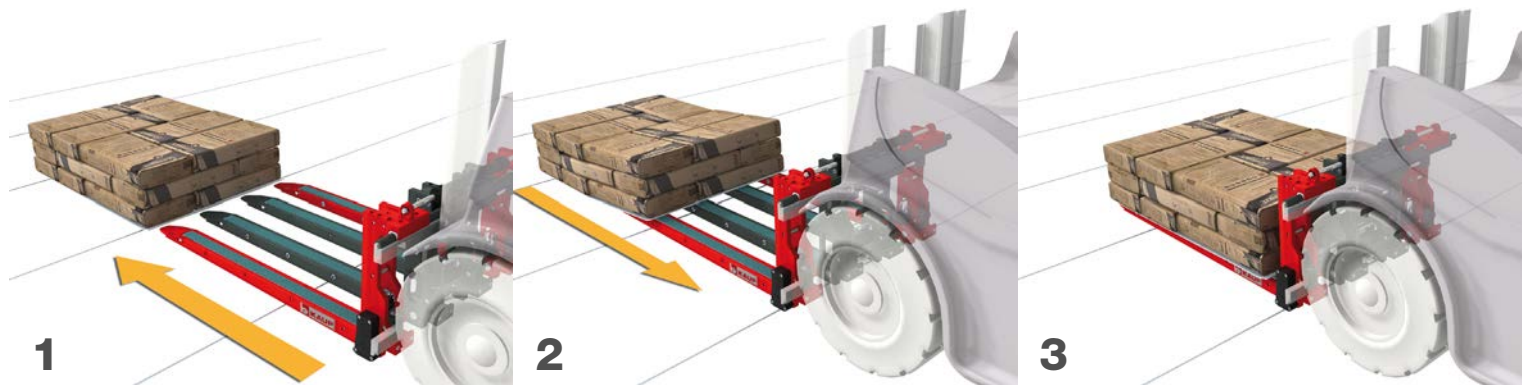

1
Approach the load, insert the fork tips underneath the load / slip-sheet and activate the conveyer belts.

2
The load is automatically pulled onto the forks as soon as the conveyer belts grip.

3
Switch off the conveyer belts as soon as the load has been completely pulled onto the forks. Setting down the load is carried out in reverse order.

Maximum performance - an attachment for all applications

Handling palletless goods

Bagged goods on slip-sheets, cartons or large surface goods which cannot be clamped - the T180FG is the ideal attachment to efficiently pick-up, transport and set down these loads. Nearly all kinds of applications can be covered with a T180FG or T180FG-2-4S which, with two fork pairs within the opening range, optimally support all loads.

Conveyor belt forks can be tailor made individually for all further applications. Fork width, number of forks and number of belts - each and every component can be specially selected to meet the specific requirements of the material handling application.

Handling palletized goods

Also perfectly suited for handling palletized goods. If handling Euro pallets length-wise or crosswise - the T180FG is as quick, safe and economic as each and every fork positioner. Furthermore the T180FG-2-4S offers even higher safety when handling Euro pallets crosswise by double support due to load distribution on 2 pairs of forks.

Your benefits at a glance

- speedy and safe handling of goods with or without pallets
- stacking loads in a second layer possible
- maximum use of height when loading and unloading containers
- maximum truck capacity and best visibility
- no need to swap attachments / trucks

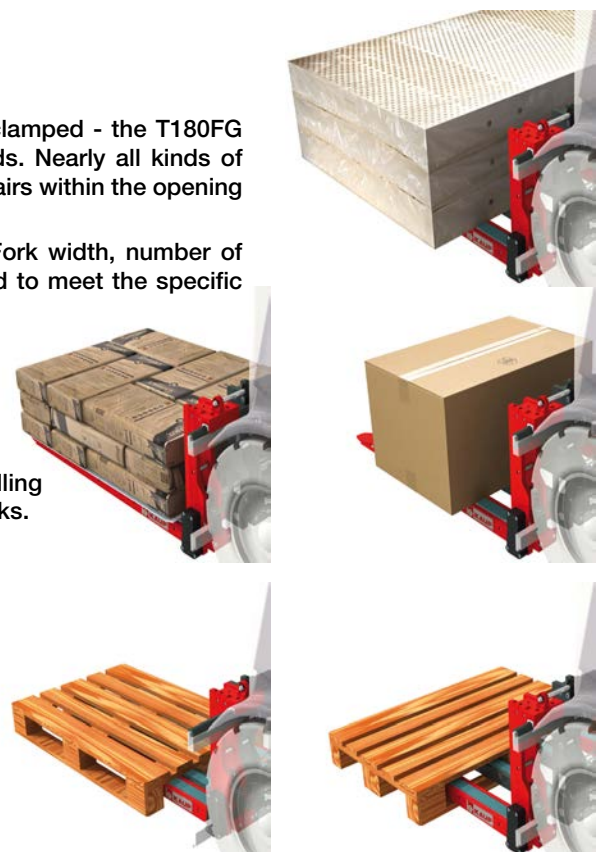



T180FG

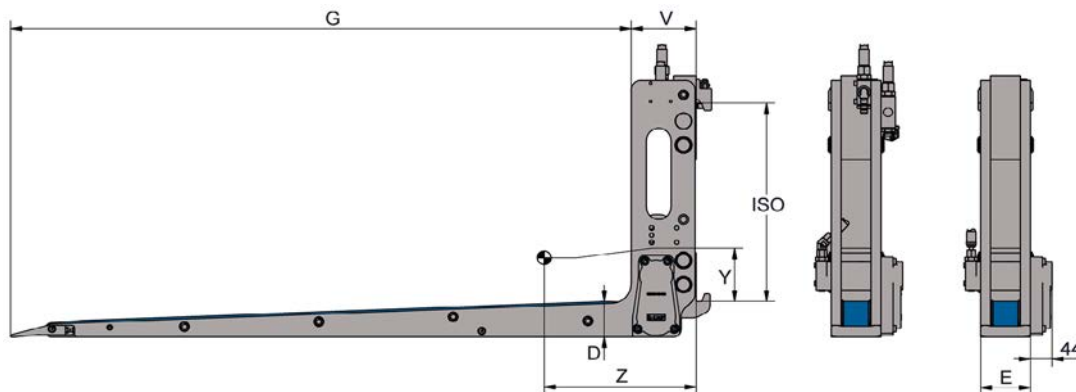

Forche a nastro T180FG

1 funzione idraulica

Modello	Portata kg	CdG mm	Dimensioni forche			Numero di nastri per forche pezzo	ISO cl.	V mm	CdG Z mm	CdG _v Y mm	Peso kg
			E mm	D mm	G mm						
1.8T180FG	1.600	600	100	74	1.250	1	2	130	317	85	119
1.8T180FG	1.200	800	100	74	1.650	1	2	130	452	68	136
1.8T180FG	800	1.250	100	74	1.970	1	2	130	567	57	149

Il numero dei nastri per forca e le dimensioni possono essere realizzati a richiesta.

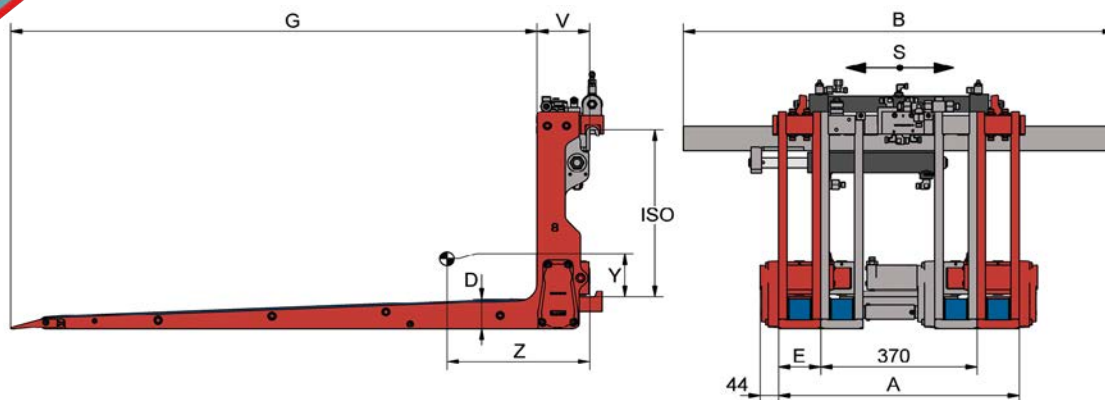
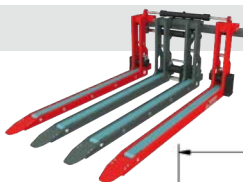

Forche telescopiche T180FG-2-4S

con traslatore semincorporato · con forche regolabili · 2 funzioni idrauliche + elettrovalvola

Modello	Tipo di pallet	Portata kg	CdG mm	S mm	Campo di apertura			E mm	D mm	G mm	ISO cl.	V mm	CdG Z mm	CdG _v Y mm	Peso kg
					A mm	B mm	E mm								
1.8T180FG-2-4S	Europallet	1.600	600	±100	570-850	1.020	100	74	1.250	2	125	326	90	225	
1.8T180FG-2-4S	Europallet	1.200	800	±100	570-850	1.020	100	74	1.650	2	125	464	71	260	

Individual solutions & options



T180FG

suitable for mounting on sideshifters or fork positioners with connection acc. to ISO 2328



T180FG-2-4S

with independent sideshift and with hydraulically adjustable forks



T180FG-4

with long forks and with load backrest for palletless handling of large surface goods

T180FG · field of application



Le attrezzature KAUP sono realizzate in conformità alle Direttive CE.
Possibilità di modifiche senza preavviso.

Il Sistema di Qualità KAUP è certificato secondo DIN ISO 9001.



Le mani per il vostro carrello

KAUP GmbH & Co. KG
Braunstrasse 17 · D - 63741 Aschaffenburg
☎ +49 6021 865-0 · 📠 +49 6021 865-213
E-Mail: kaup@kaup.de · www.kaup.de



Distributore esclusivo per l'Italia:

ABG srl
Via Tobagi 32 · Loc. Crocetta · I - 29027 Podenzano (PC)
☎ +39 0523 760662 · 📠 +39 0523 763676
E-Mail: info@abg-srl.it · Internet: www.abg-srl.it